

System Block:

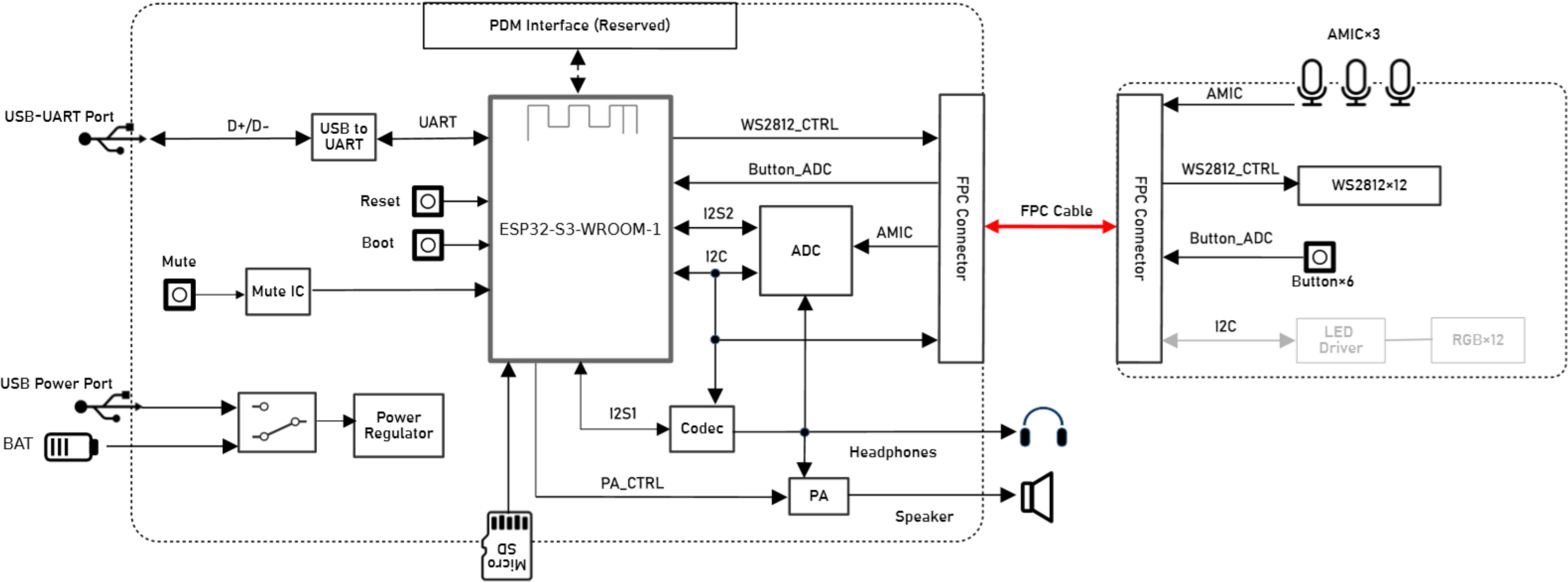

To ADC

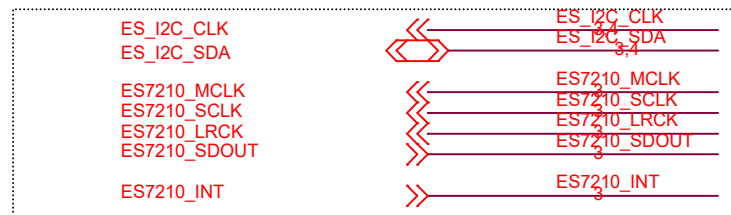

To Codec

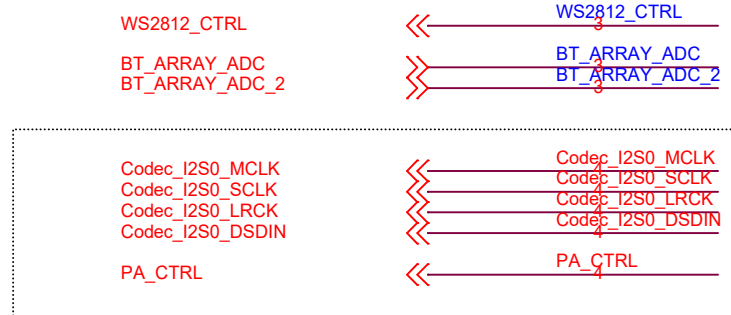

UART & Download

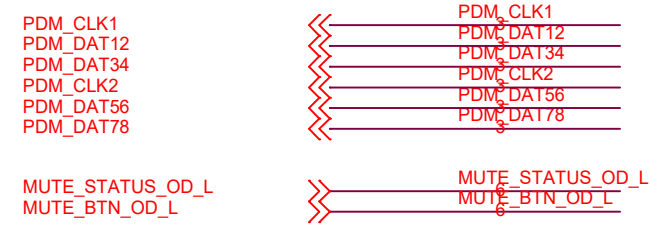

ESP32-S3 Module:

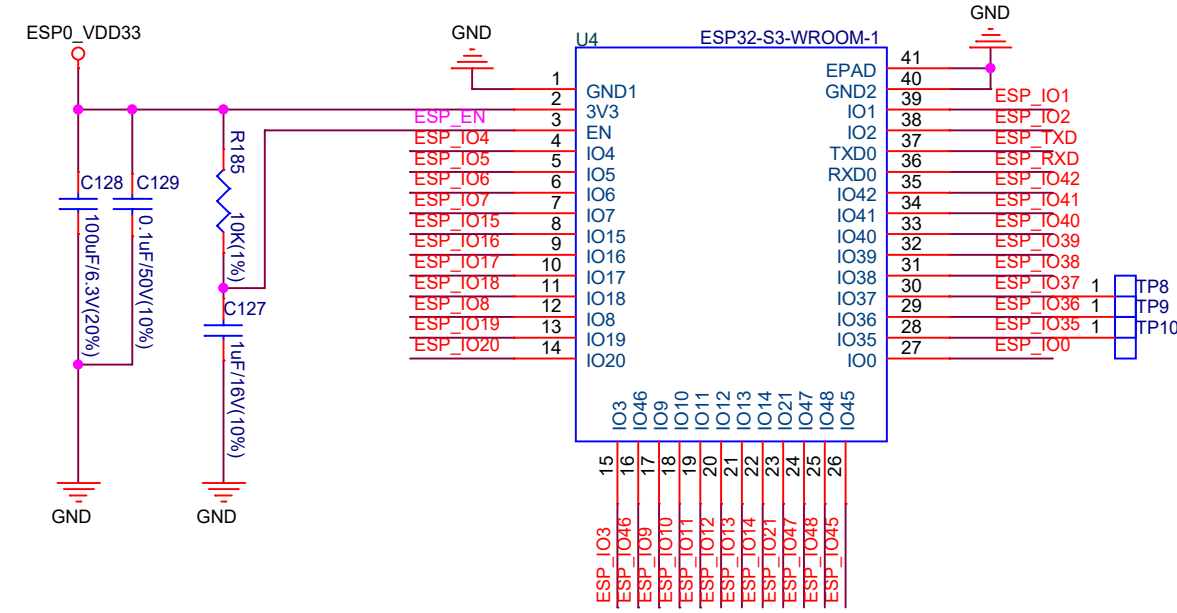

ESP0 Pin Configuration:

Codec_I2S0_MCLK	R292	0R(1%)(NC)	ESP_IO42
Codec_I2S0_LRCK	R289	0R(1%)(NC)	ESP_IO41
Codec_I2S0_SCLK	R291	0R(1%)(NC)	ESP_IO40
Codec_I2S0_DSDIN	R282	0R(1%)(NC)	ESP_IO39
PA_CTRL	R284	0R(1%)(NC)	ESP_IO38
ES_I2C_SDA	R288	0R(1%)(NC)	ESP_IO1
ES_I2C_CLK	R302	0R(1%)(NC)	ESP_IO2
ESP_SDIO_CLK	R303	0R(1%)(NC)	ESP_IO21
ESP_SDIO_CMD	R308	0R(1%)(NC)	ESP_IO14
ESP_SDIO_DAT0	R304	0R(1%)(NC)	ESP_IO13
ESP_SDIO_DAT1	R306	0R(1%)(NC)	ESP_IO3
ES7210_INT	R313	0R(1%)(NC)	ESP_IO12
ES7210_SDOU1	R314	0R(1%)(NC)	ESP_IO11
ES7210_SCLK	R299	0R(1%)(NC)	ESP_IO10
ES7210_LRCK	R300	0R(1%)(NC)	ESP_IO9
ES7210_MCLK	R307	0R(1%)(NC)	ESP_IO20
BT_ARRAY_ADC_2	R316	0R(1%)(NC)	ESP_IO8
BT_ARRAY_ADC	R297	0R(1%)(NC)	ESP_IO19
ESP0_LED	R293	0R(1%)(NC)	ESP_IO19
WS2812_CTRL	R312	0R(1%)(NC)	ESP_IO19
ESP0_SD_CLK	R305	0R(1%)(NC)	ESP_IO18
ESP0_SD_CMD	R281	51R(1%)(NC)	ESP_IO17
ESP0_SD_DAT0	R285	51R(1%)(NC)	ESP_IO16
ESP0_SD_DAT1	R287	0R(1%)(NC)	ESP_IO15
ESP0_SD_DET	R286	51R(1%)(NC)	ESP_IO7
ESP0_Boot_IO0	R294	0R(1%)(NC)	ESP_IO0
ESP0_Boot_IO2	R296	0R(1%)(NC)	ESP_IO2
ESP0_Boot_EN	R295	0R(1%)(NC)	ESP_EN
PDM_CLK1	R283	0R(1%)(NC)	ESP_IO4
PDM_DAT12	R290	0R(1%)(NC)	ESP_IO5
PDM_DAT34	R290	0R(1%)(NC)	ESP_IO6
PDM_CLK2	R280	0R(1%)(NC)	ESP_IO45
PDM_DAT56	R309	0R(1%)(NC)	ESP_IO45
PDM_DAT78	R310	0R(1%)(NC)	ESP_IO46
MUTE_STATUS_OD_L	R343	0R(1%)(NC)	ESP_IO47
MUTE_BTN_OD_L	R344	0R(1%)(NC)	ESP_IO48

Connect between ESPs
1bit mode

ESP to MicroSD Card
SPI Mode

Strapping Pins

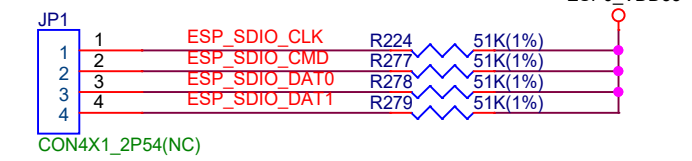
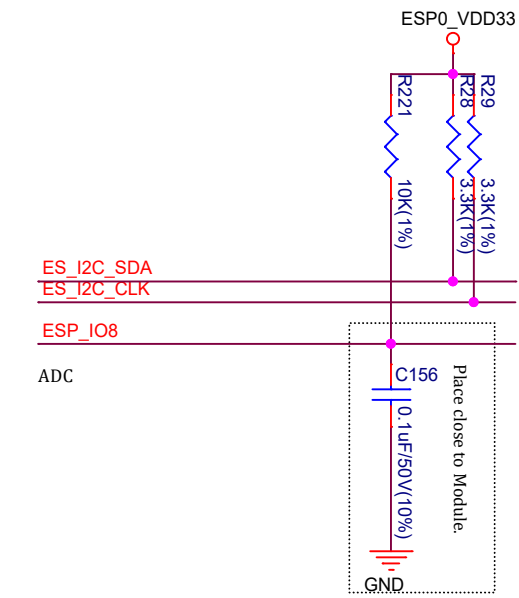
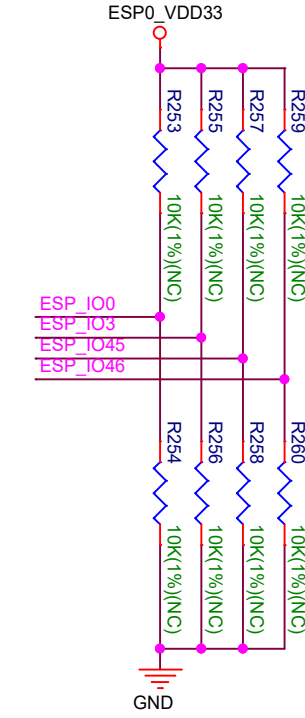

Notes:
1. Reserved SDIO 1-bit for communicating with another esp system.

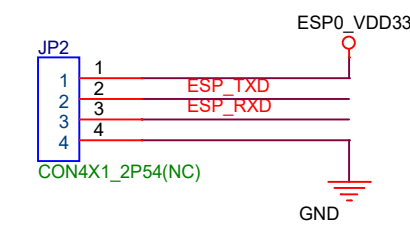

+5V -> 3.3V:

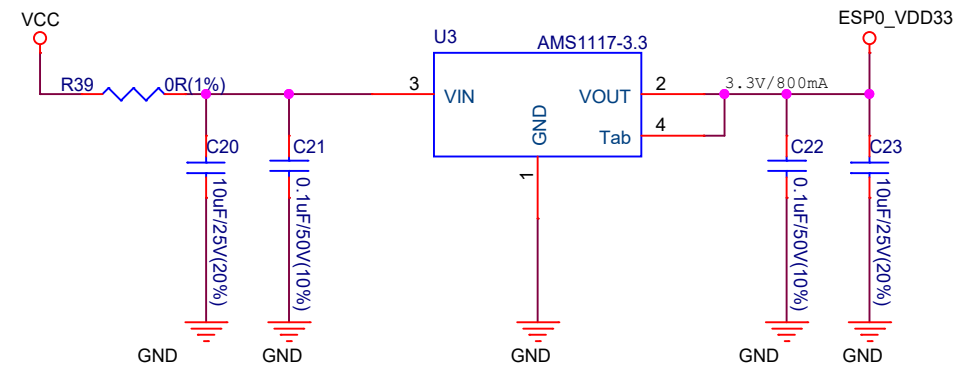

LED Indication:

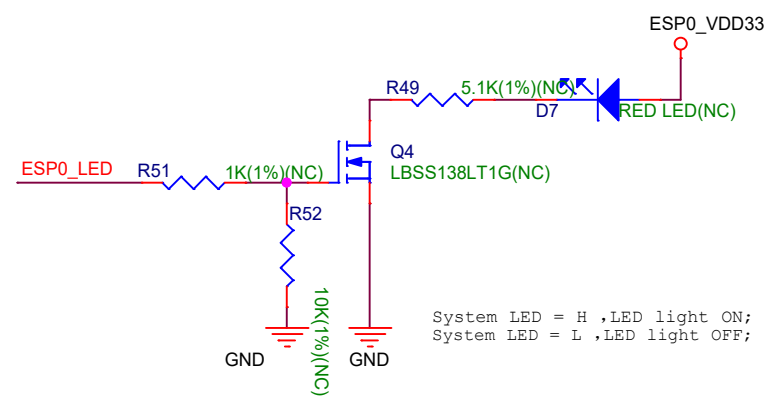

System LED = H ,LED light ON;
System LED = L ,LED light OFF;

ESP32 Module:

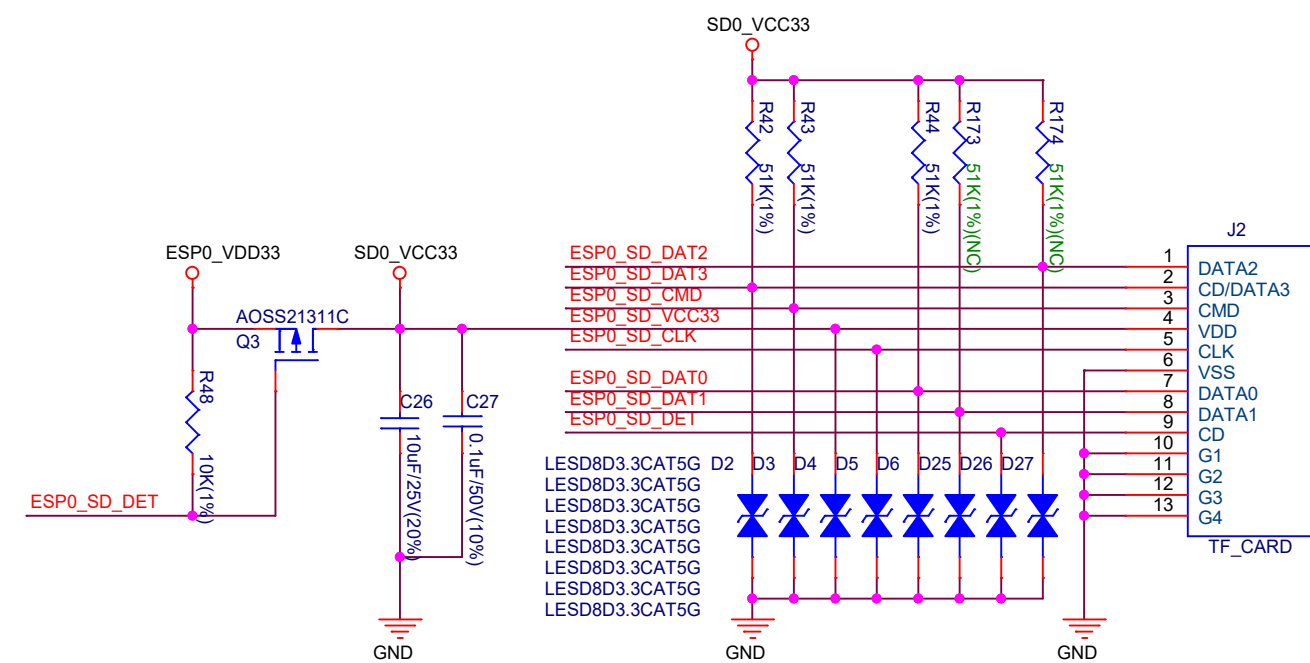

MicroSD Card SPI mode:
1. DAT3 works as CS(chip select);
2. CMD works as DI(Data In);
3. CLK works as Clock;
4. DAT0 works as DO(Data out).

ESPRESSIF

乐鑫信息科技(上海)股份有限公司

Title		
ESP32-S3-Korvo		
Size	Document Number	Rev
C	<02_ESP0>	V5
Date:	Wednesday, October 20, 2021	Sheet 2 of 6

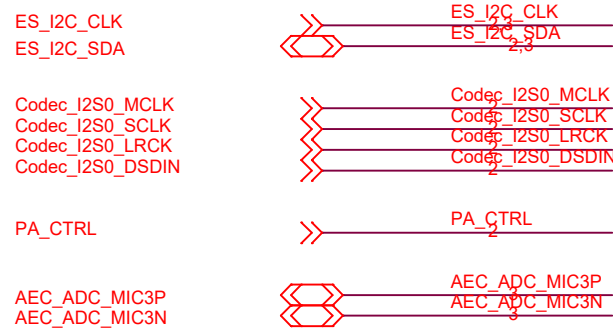

Power for Codec:

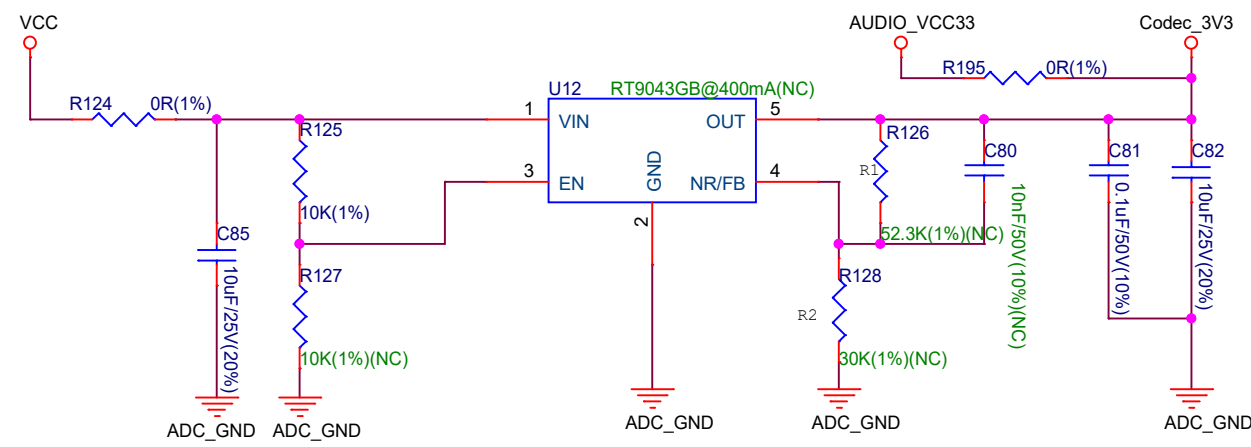

Notes:
 1. $V_{out} = 1.20 * (1 + R1/R2) = 3.296V$;
 R1=52.3K, R2=30.1K are recommended for better performance.

Codec:

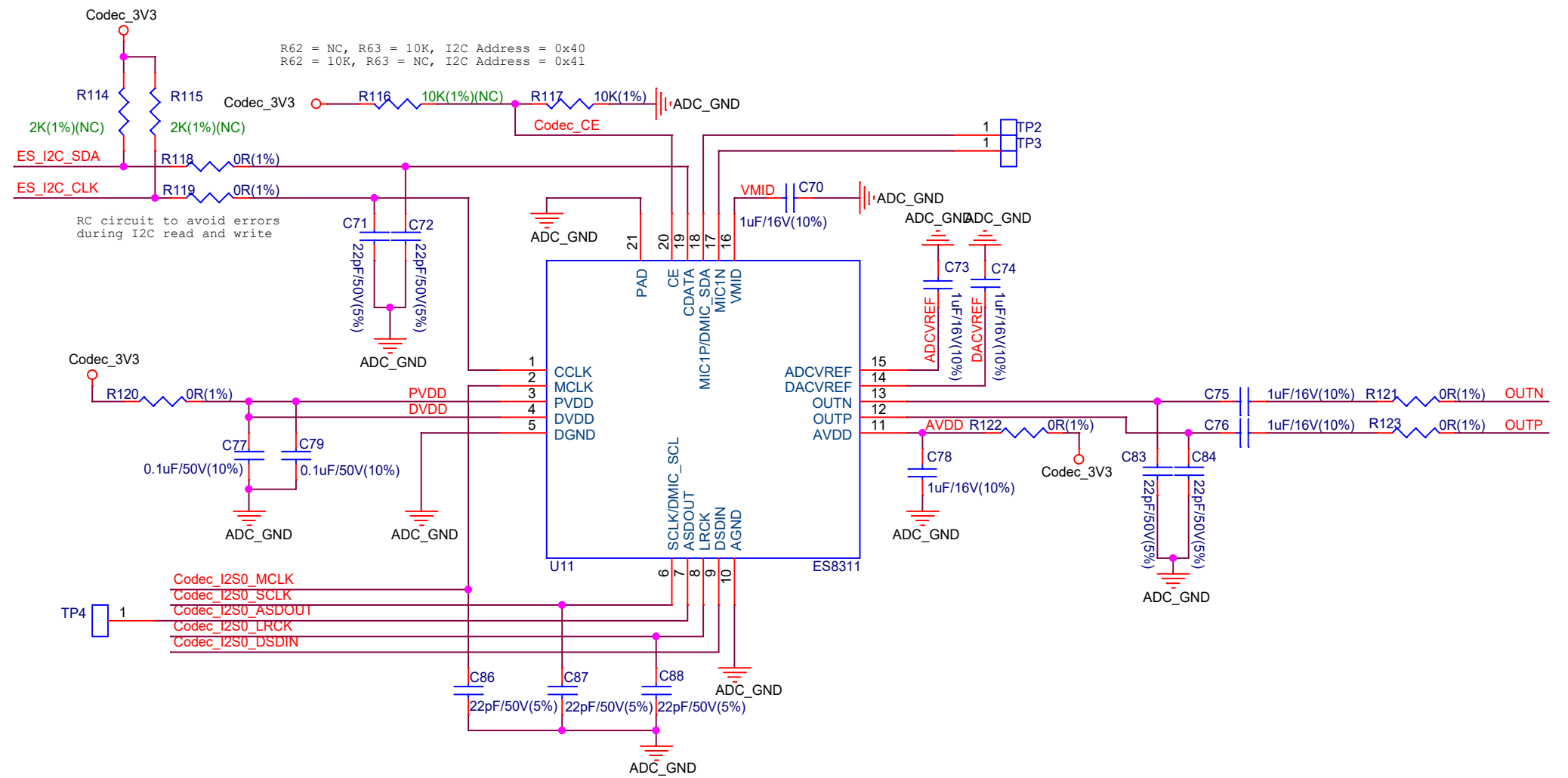

AEC:

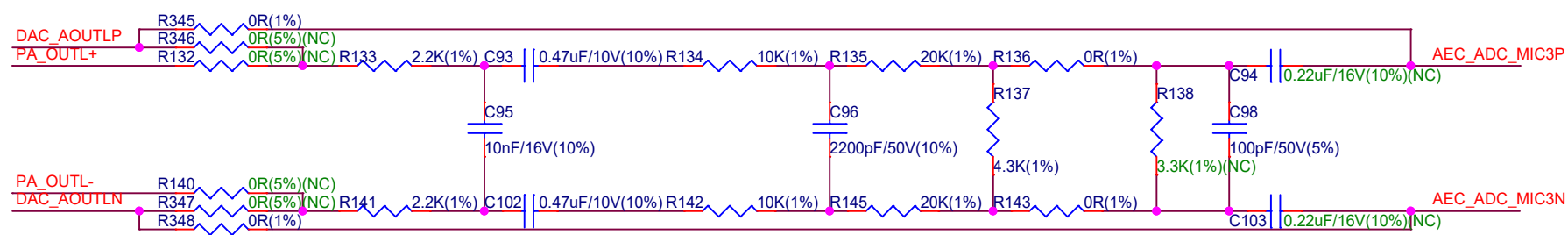

PA & Speaker:

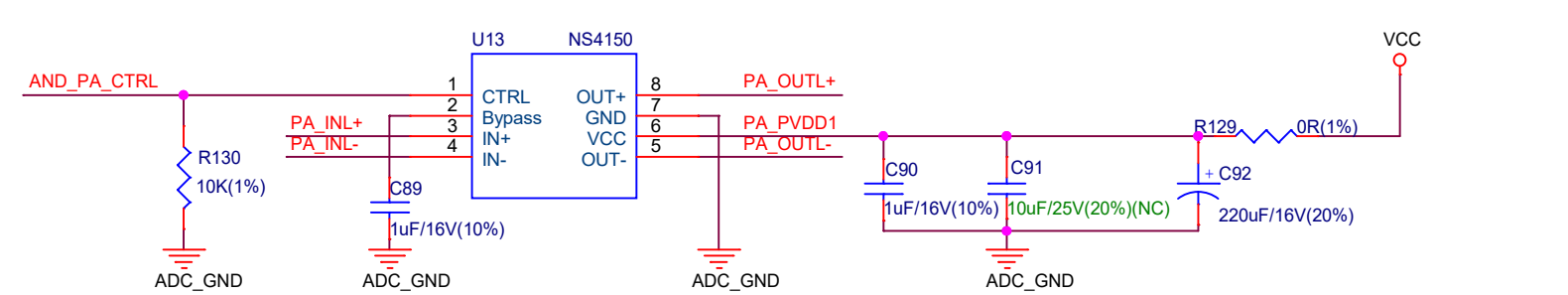

EarPhone:

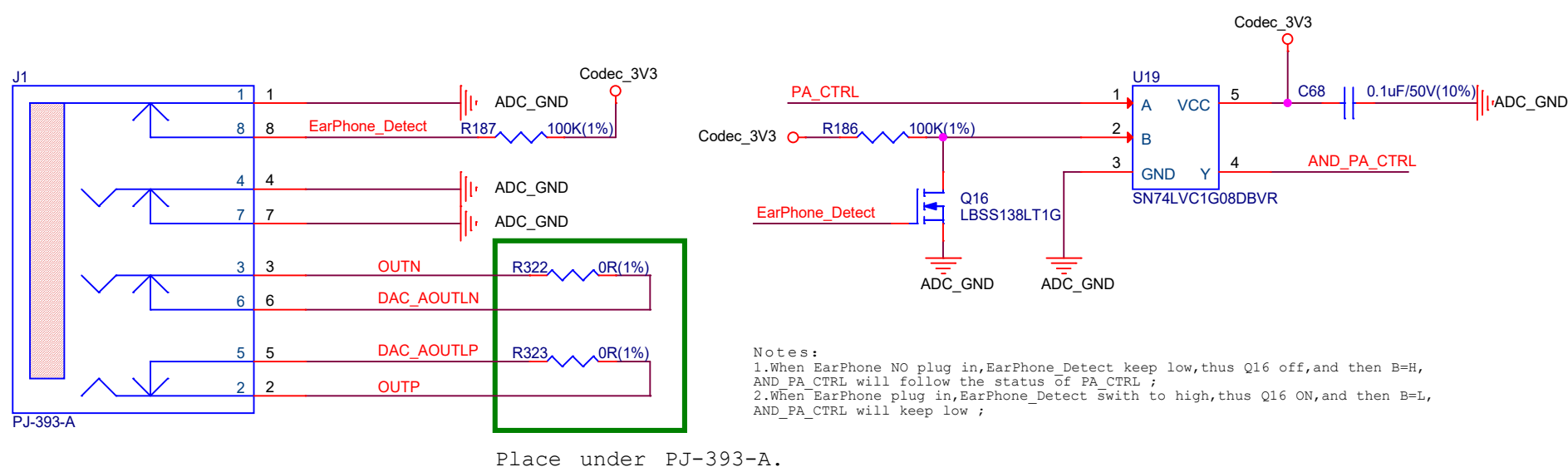

Notes:
 1. When EarPhone NO plug in, EarPhone_Detect keep low, thus Q16 off, and then B=H, AND PA_CTRL will follow the status of PA_CTRL ;
 2. When EarPhone plug in, EarPhone_Detect switch to high, thus Q16 ON, and then B=L, AND PA_CTRL will keep low ;

Place under PJ-393-A.

ESPRESSIF

乐鑫科技(上海)股份有限公司

Title		
ESP32-S3-Korvo		
Size	Document Number	Rev
C	<04_ESP0_Codec_PA>	V5
Date:	Friday, October 22, 2021	Sheet 4 of 6

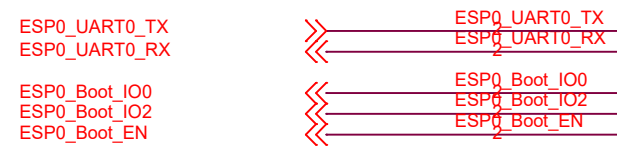

BATTERY:

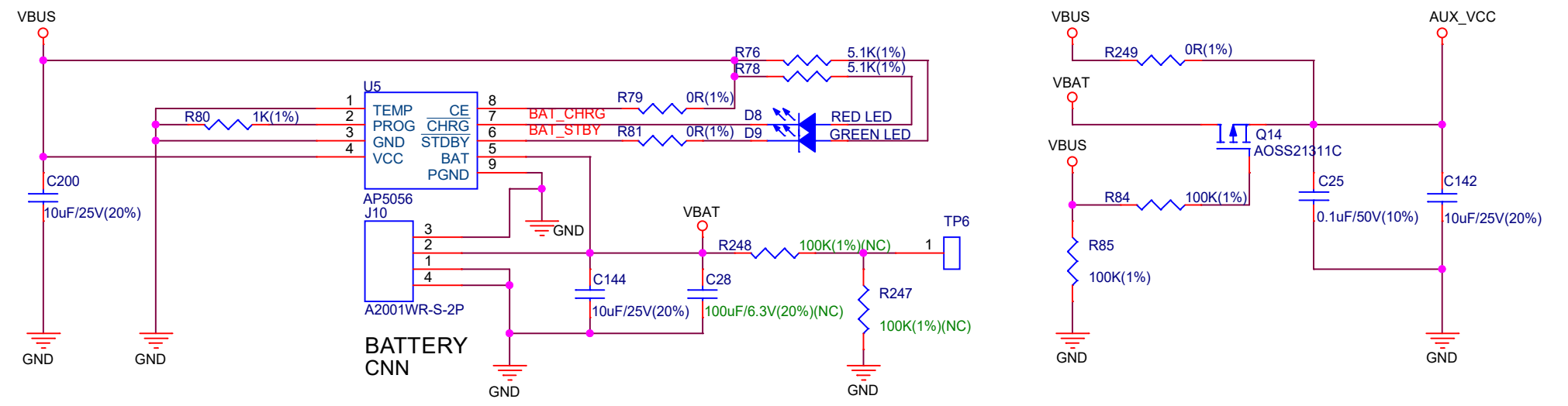

Power IN:

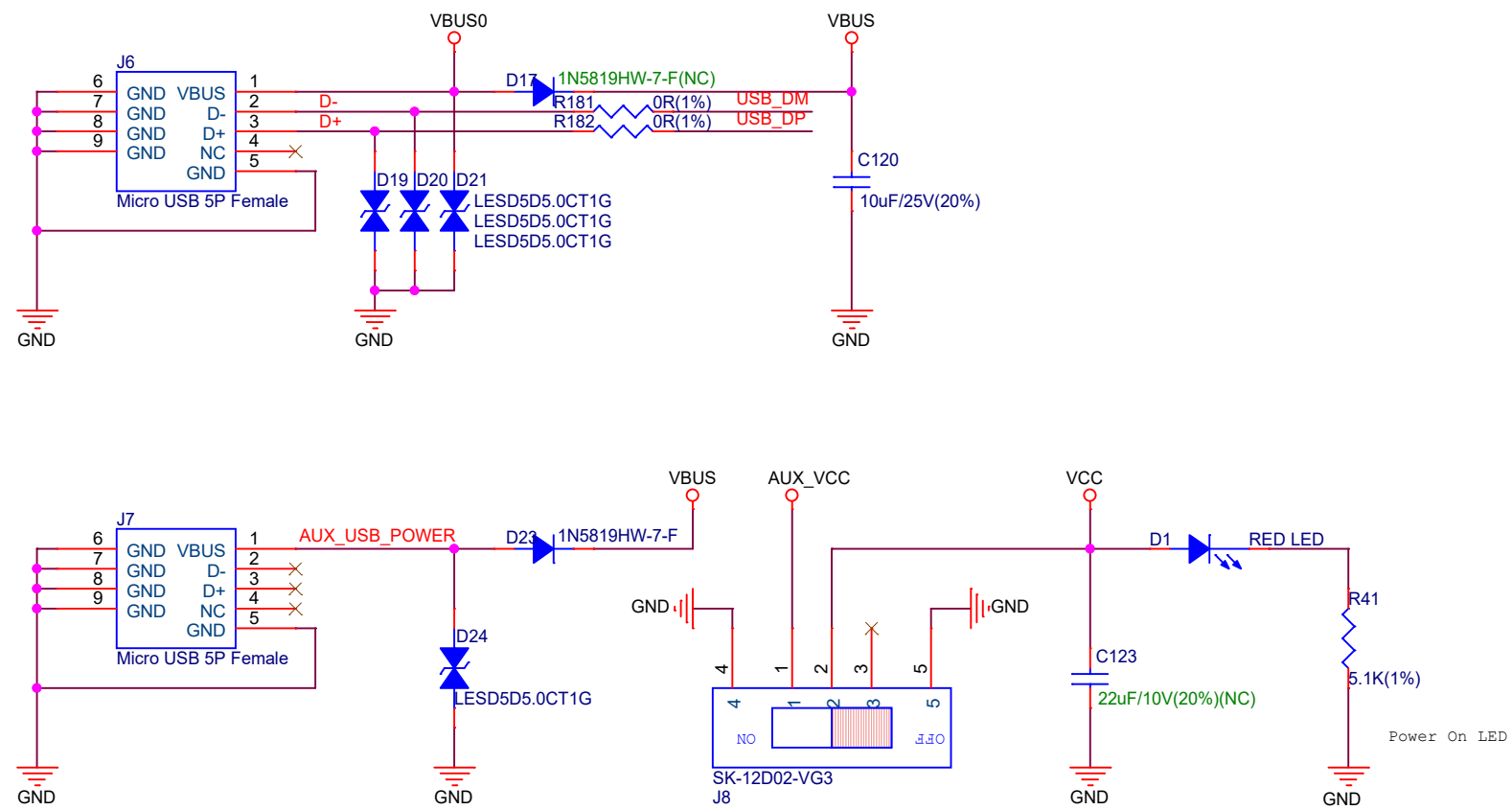

UART:

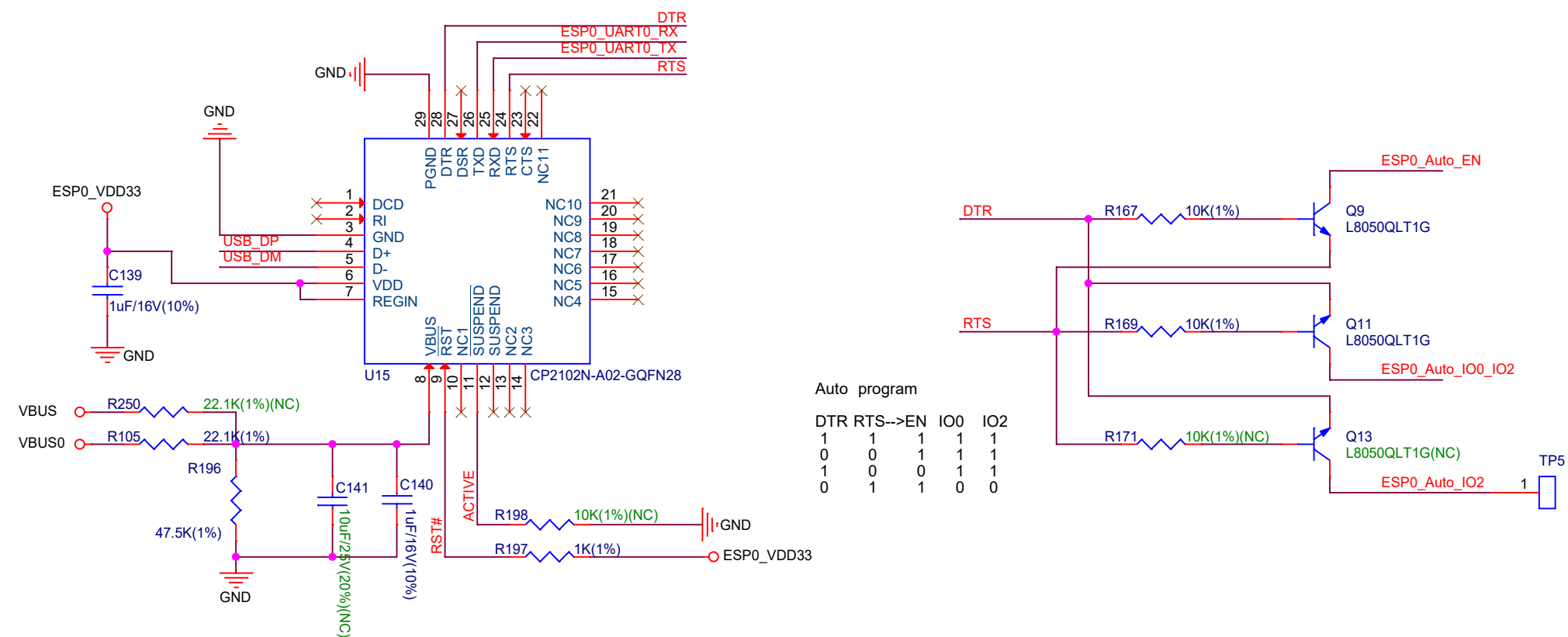

Reset & Download & Button:



ESPRESSIF

乐鑫信息科技(上海)股份有限公司

Title ESP32-S3-Korvo

Size Document Number

C <05_Power_UART>

Date: Wednesday, October 20, 2021

Sheet 5 of 6

Rev V5

