

System Block:

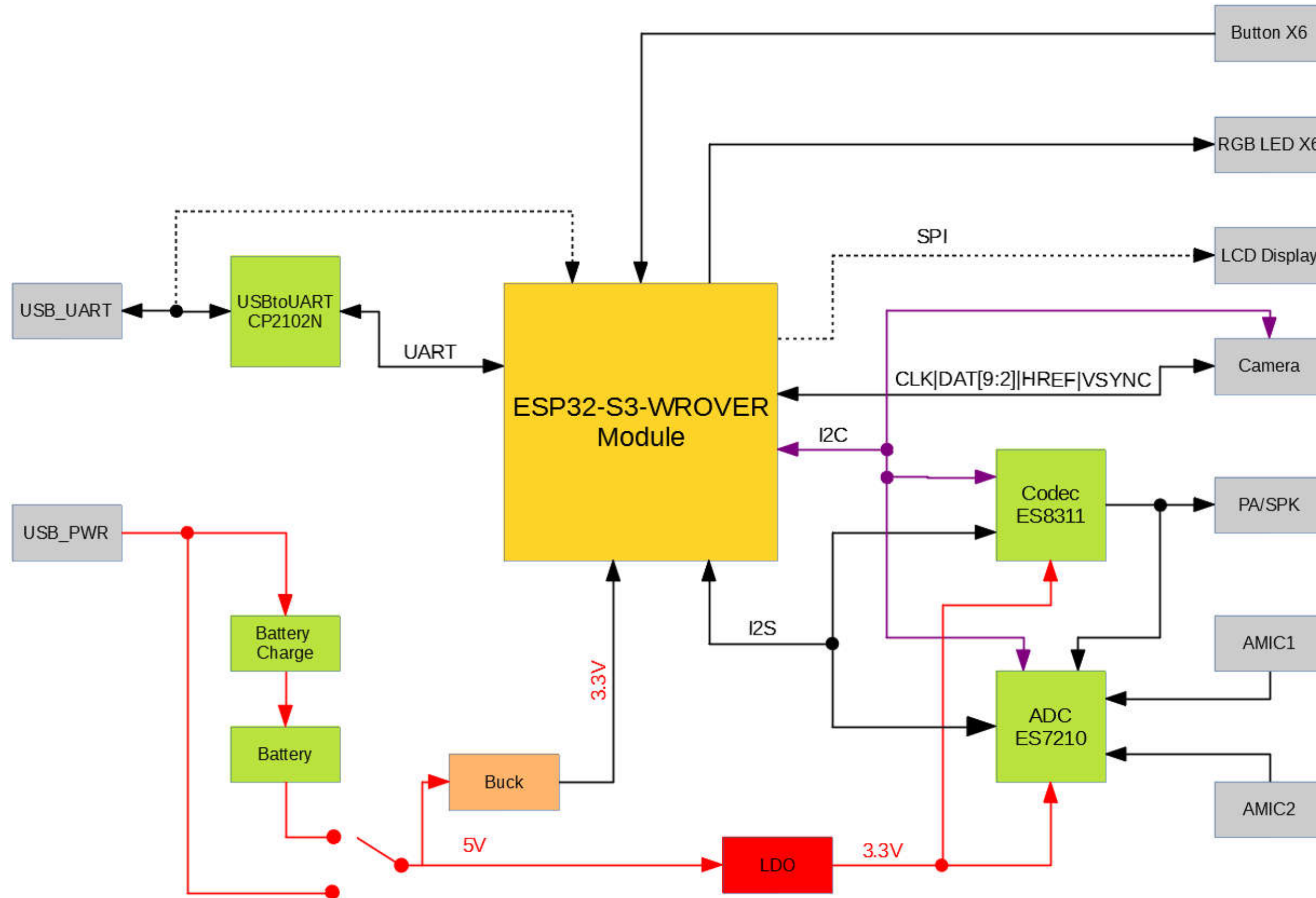

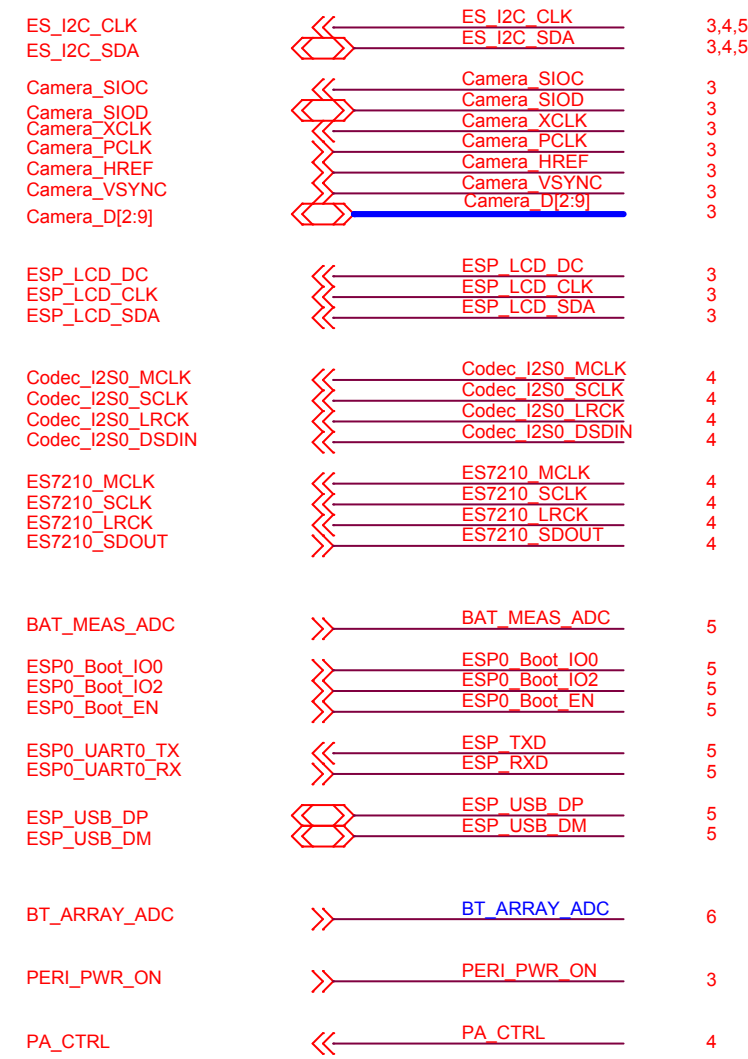

ESP32-WRVER/ESP32-724-WROVER/ESP32-S3-WROVER:

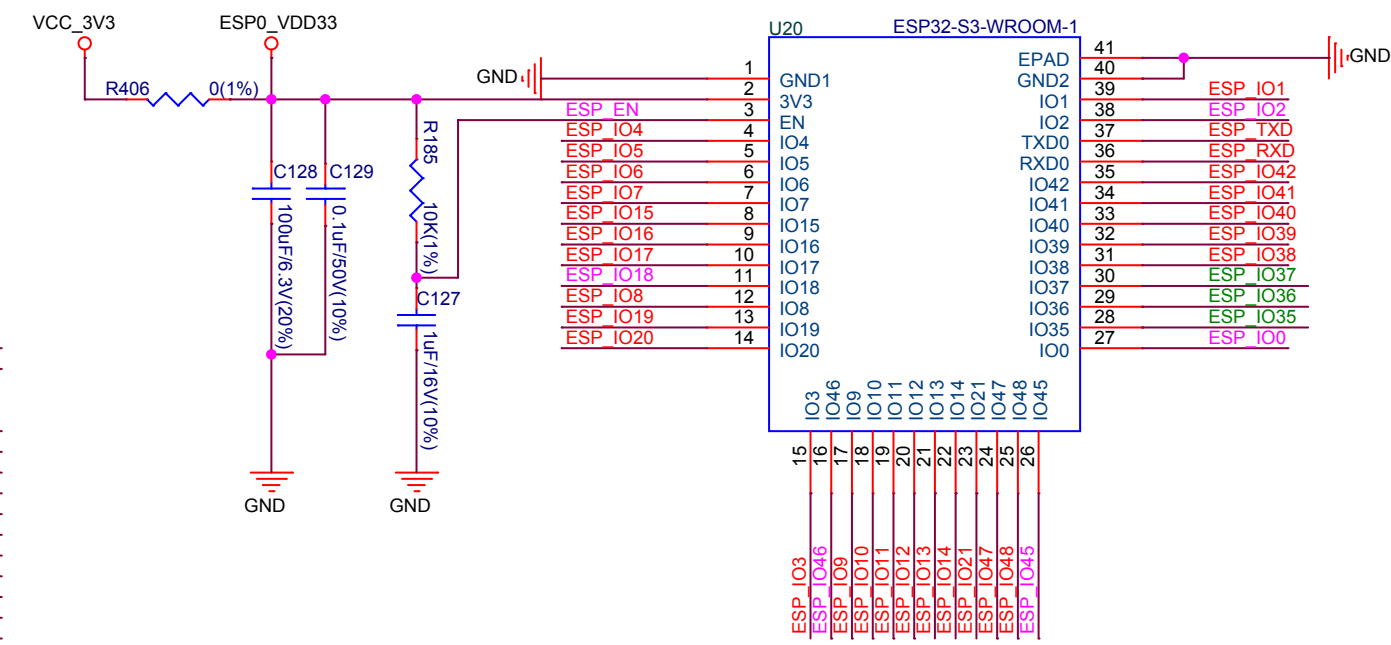

ESP Module Pin Configuration:

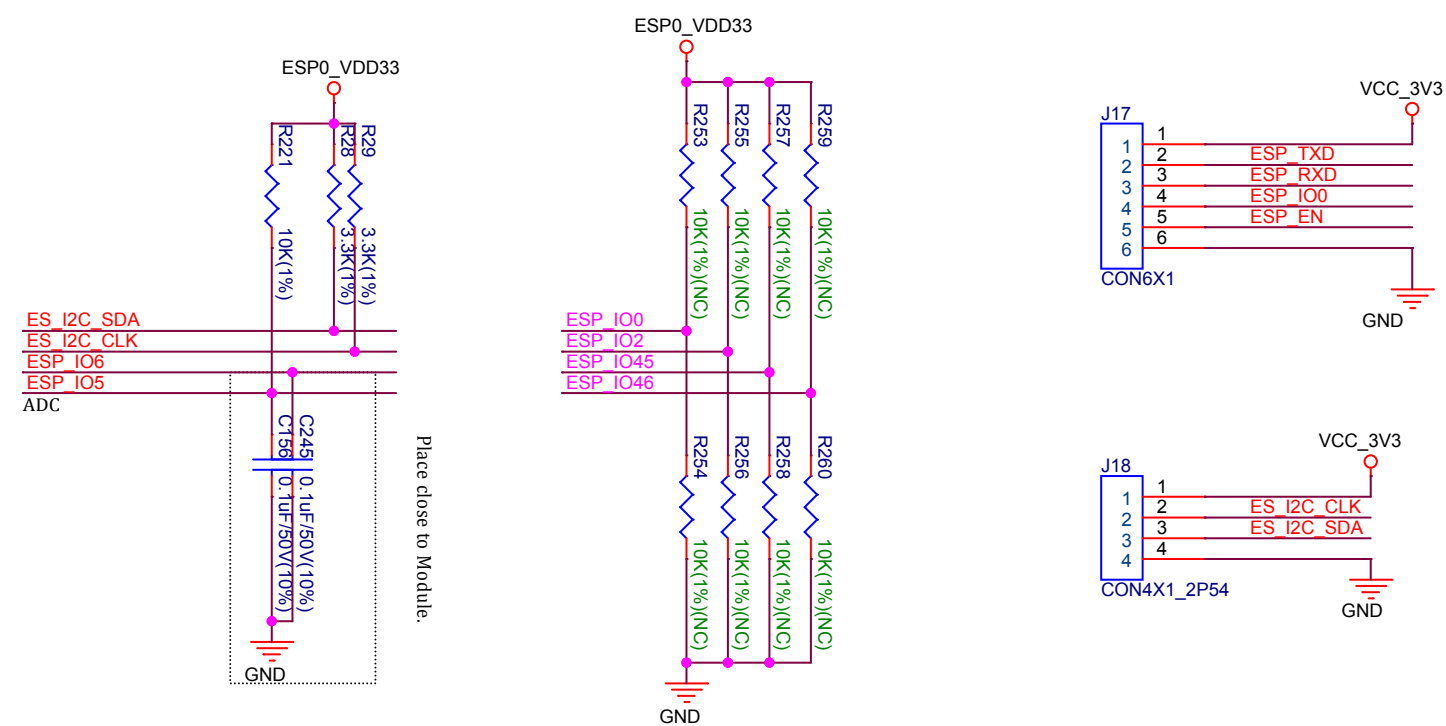
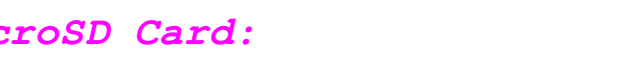
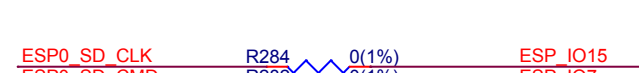
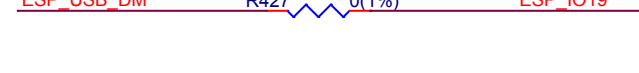
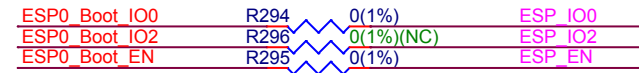
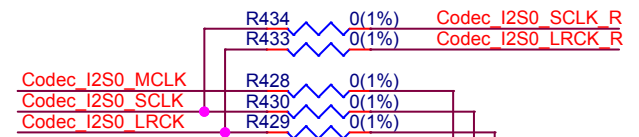
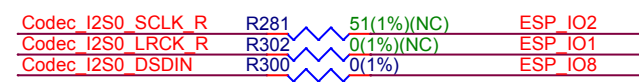
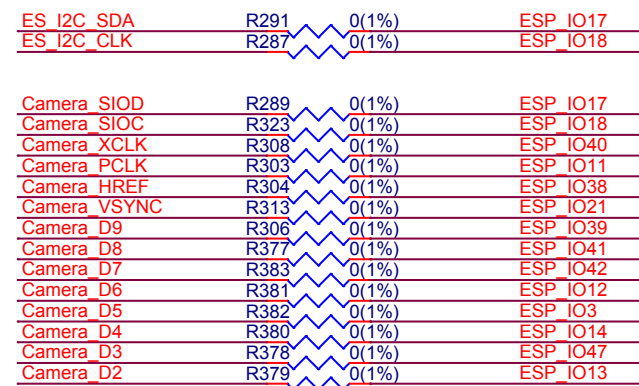

Power Regulator: 5 -> 3.3V

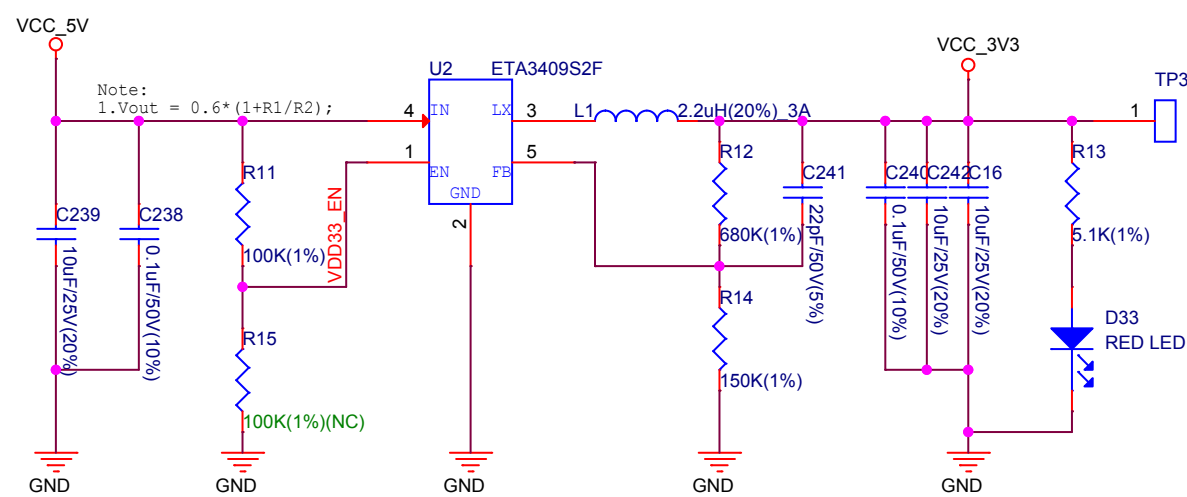

Peripherals Power:

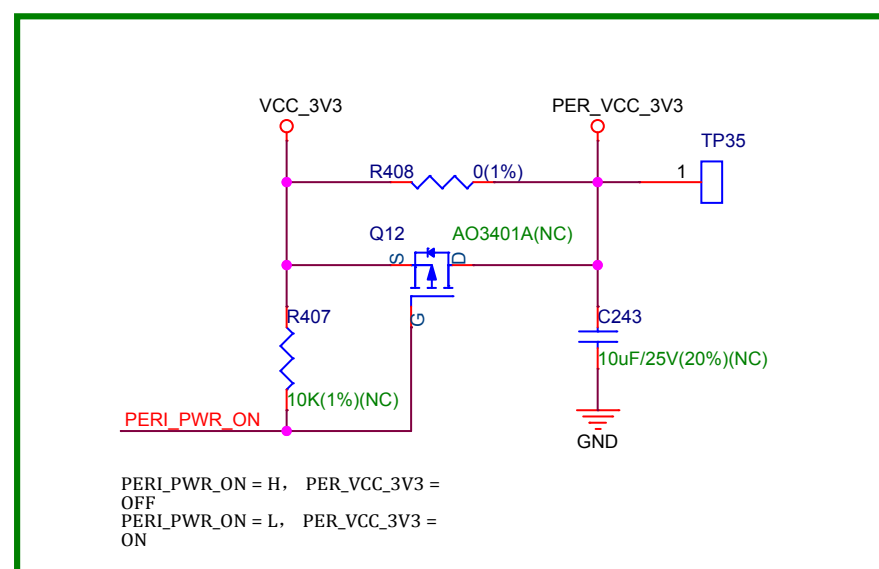

MicroSD Card:

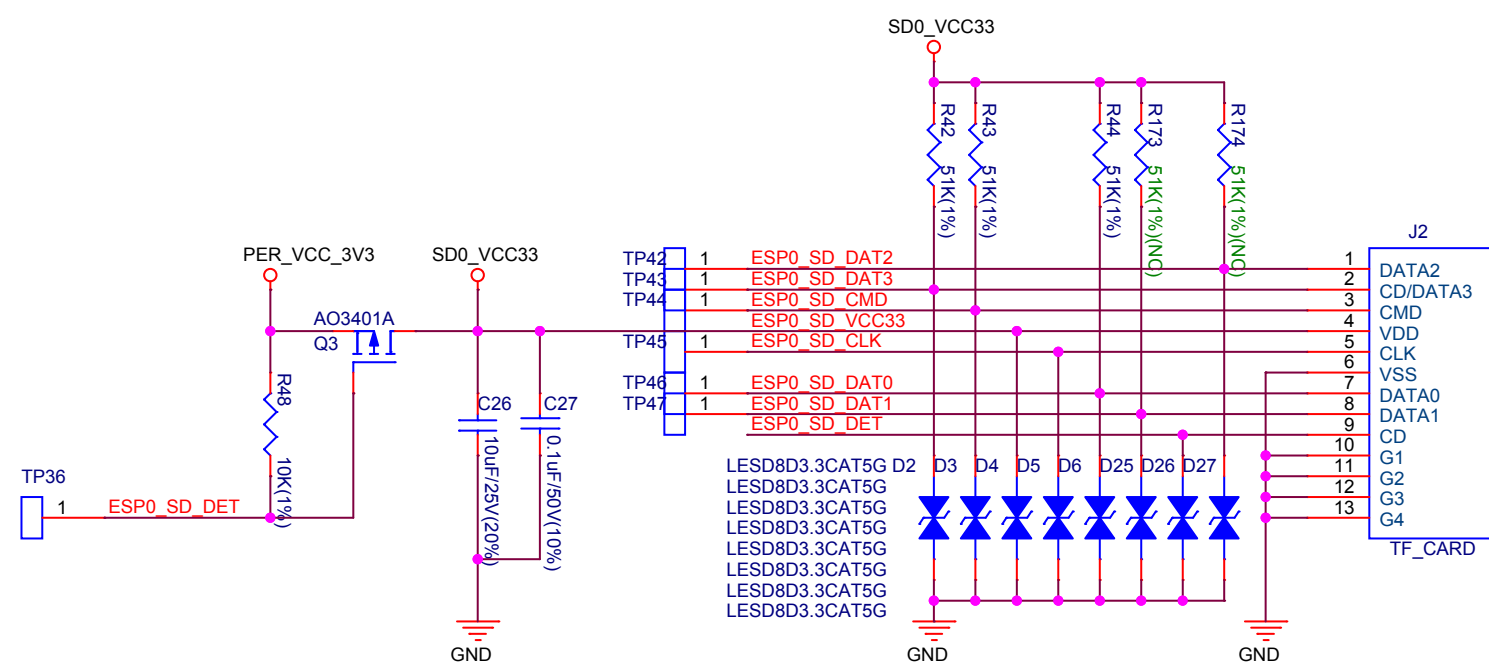

MicroSD Card SPI mode:
 1. DAT3 works as CS(chip select);
 2. CMD works as DI(Data In);
 3. CLK works as Clock;
 4. DAT0 works as DO(Data out).

ESPRESSIF

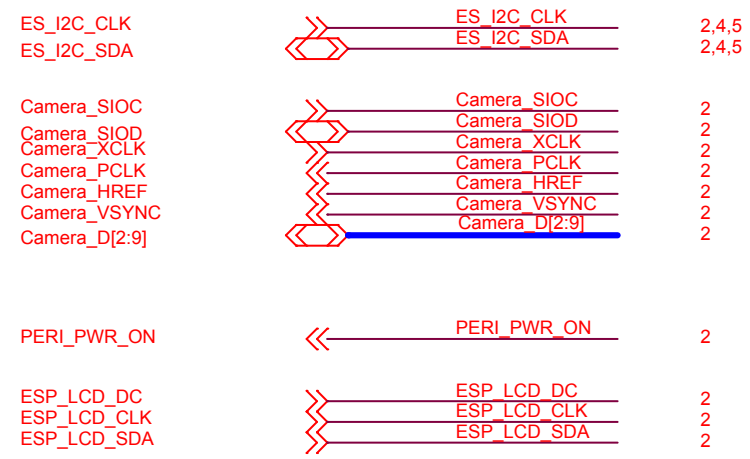

I/O Expander:

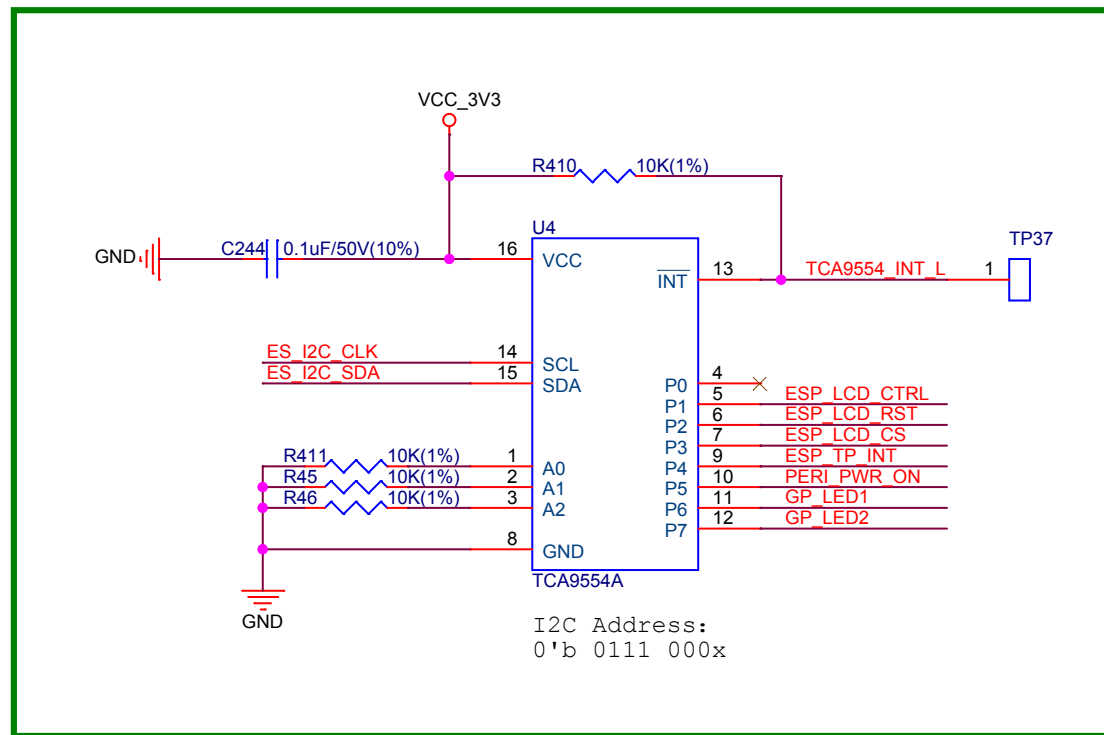

Camera:

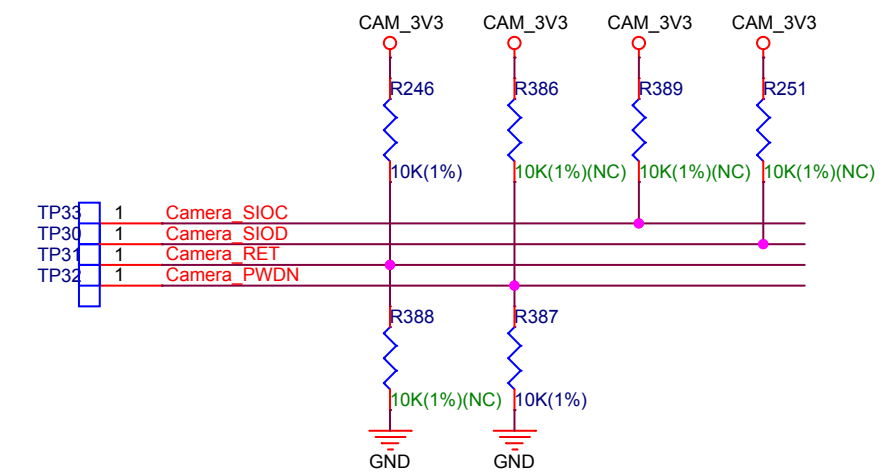
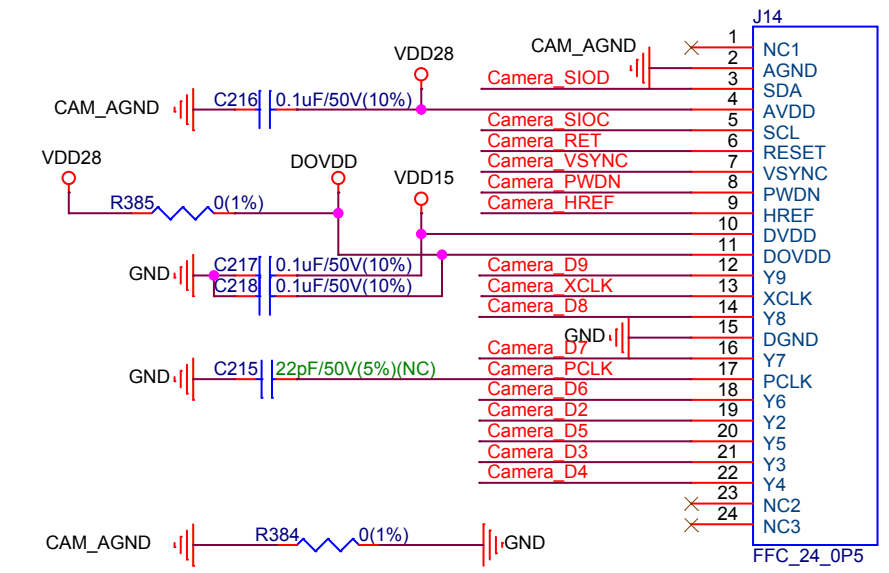
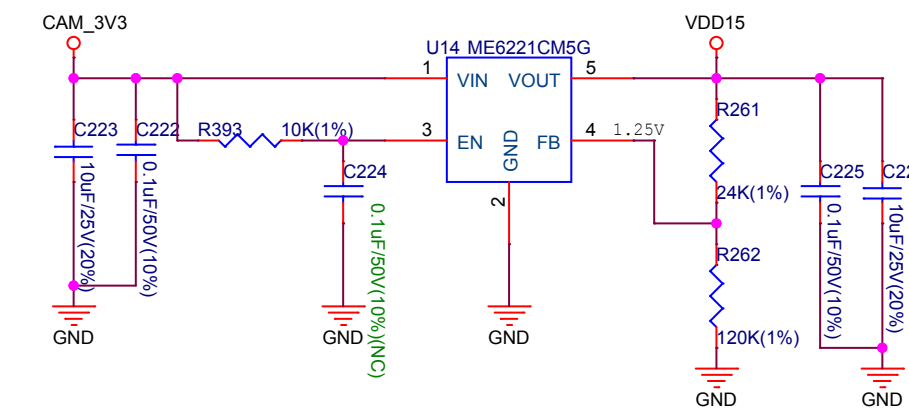
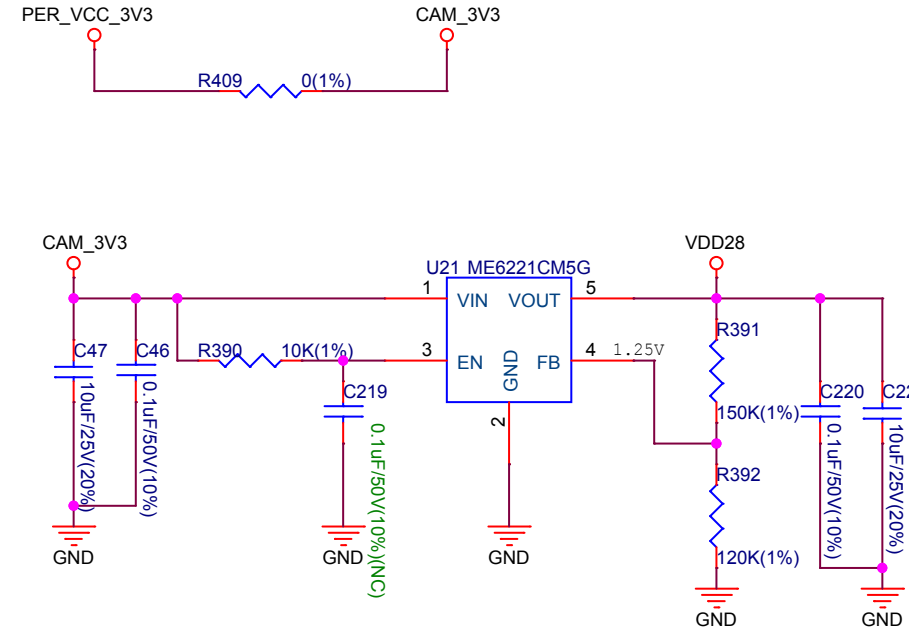

FPC for LCD Display:

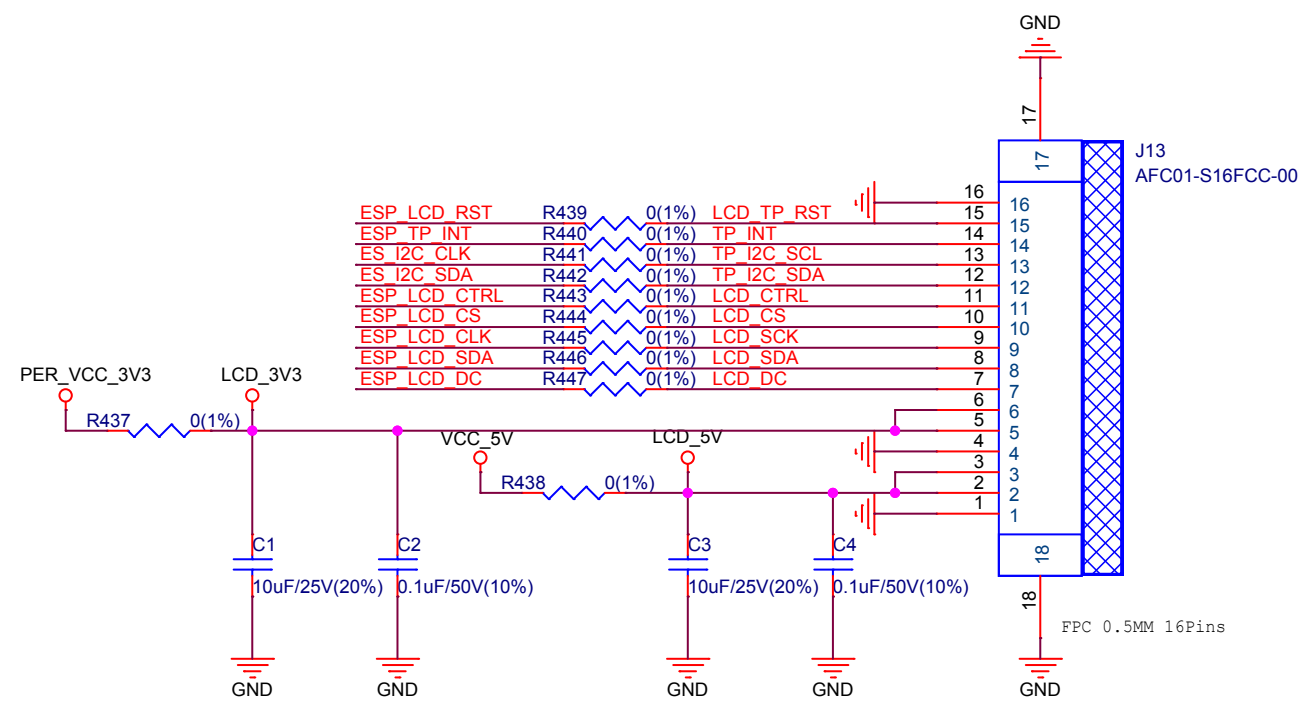

General LEDs:

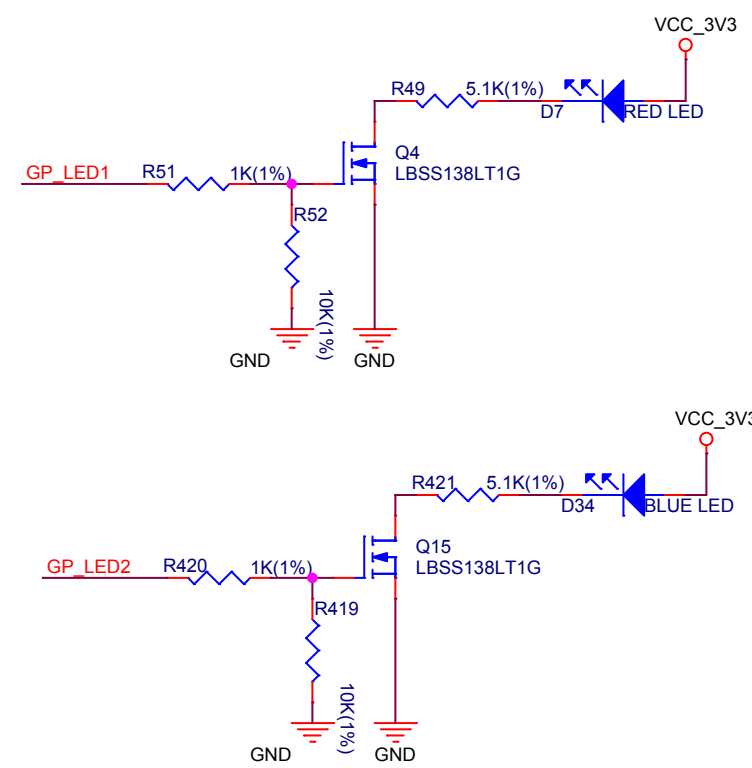

Location Holes:

Support Board

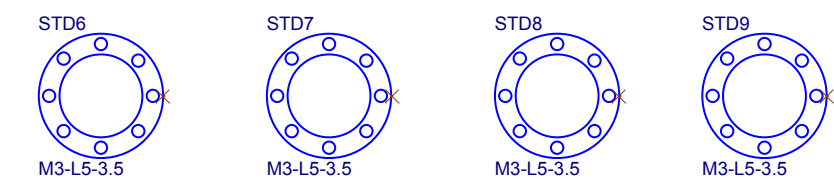

Support LCD

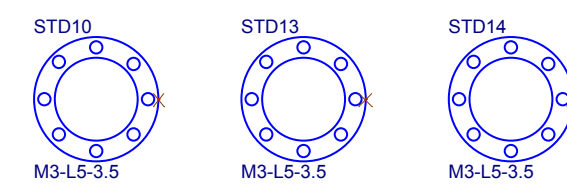

Support Camera.

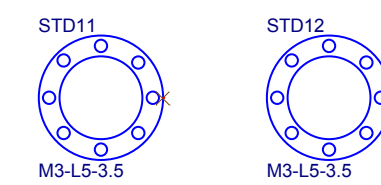

ESPRESSIF

乐鑫信息科技(上海)股份有限公司

Title: ESP32-S3-Korvo-2

Size: Document Number
C: 03_CAM_LCD Rev: 3.1.2

Date: Tuesday, January 16, 2024 Sheet 3 of 6

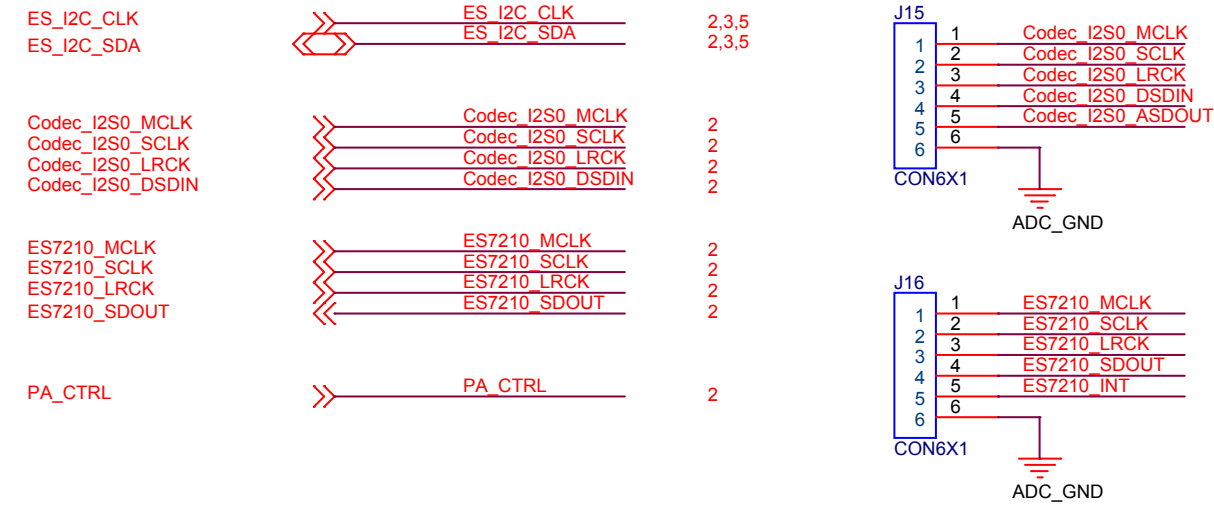

Power for Codec:

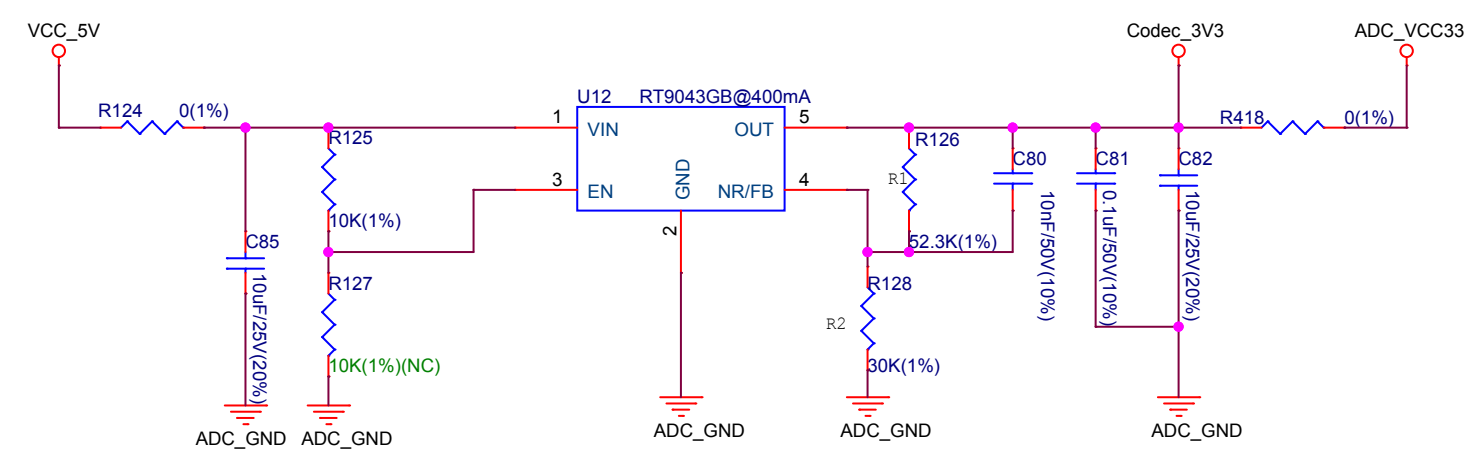

AEC:

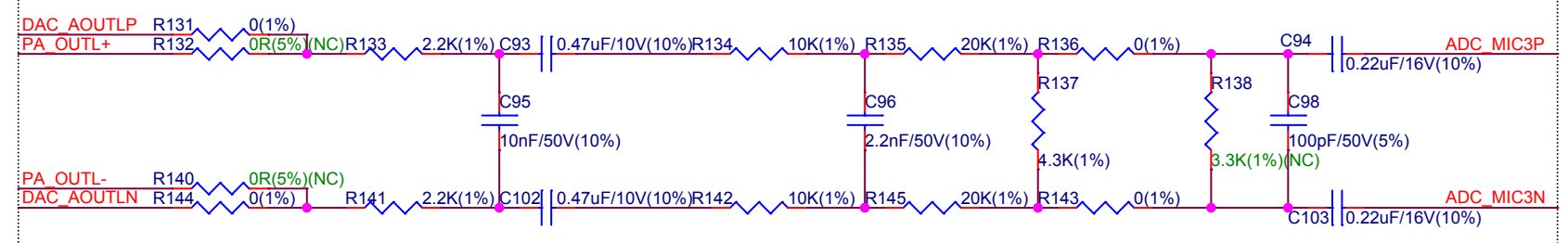

PA & Speaker:

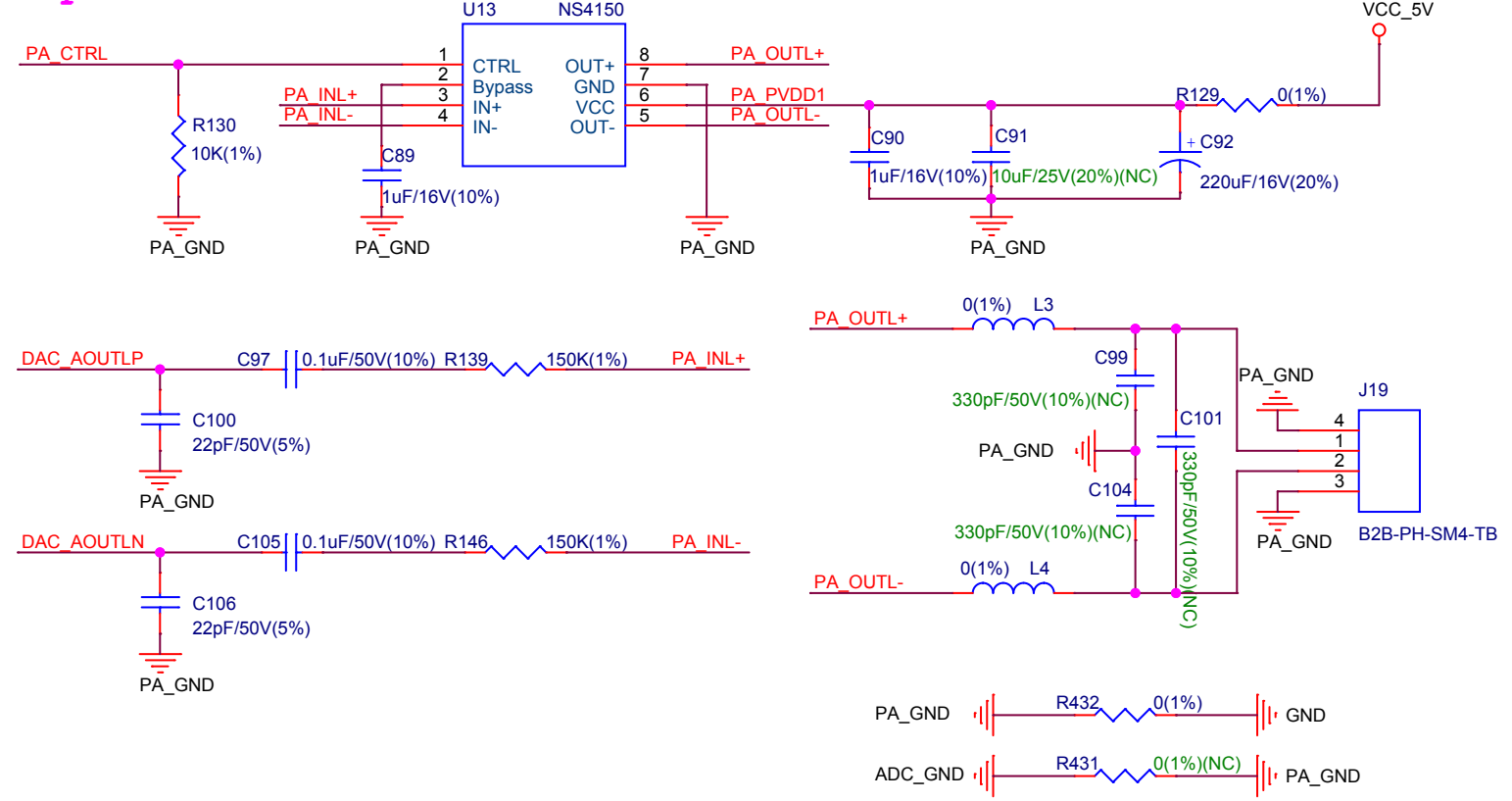

Codec:

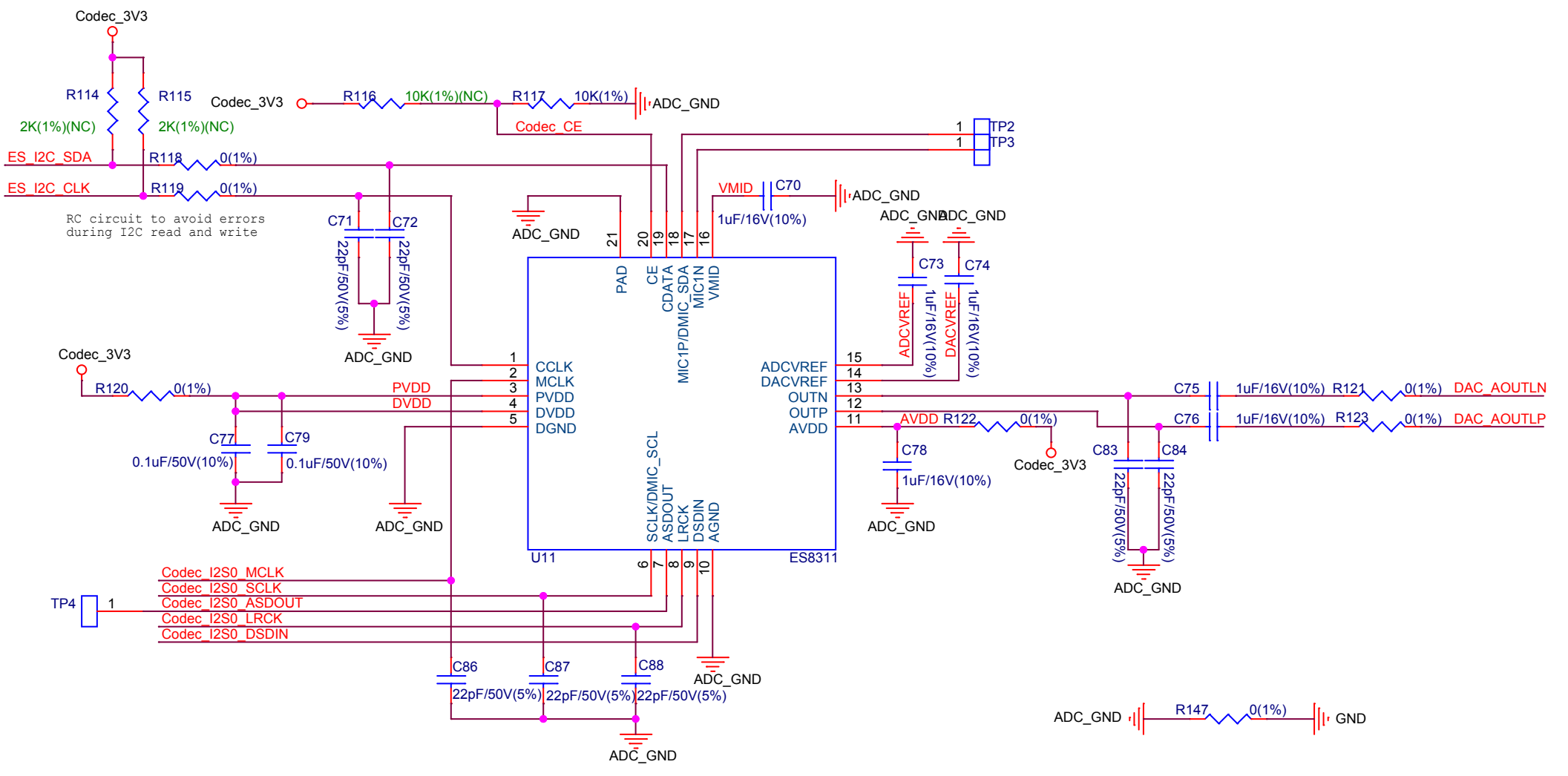

ADC:

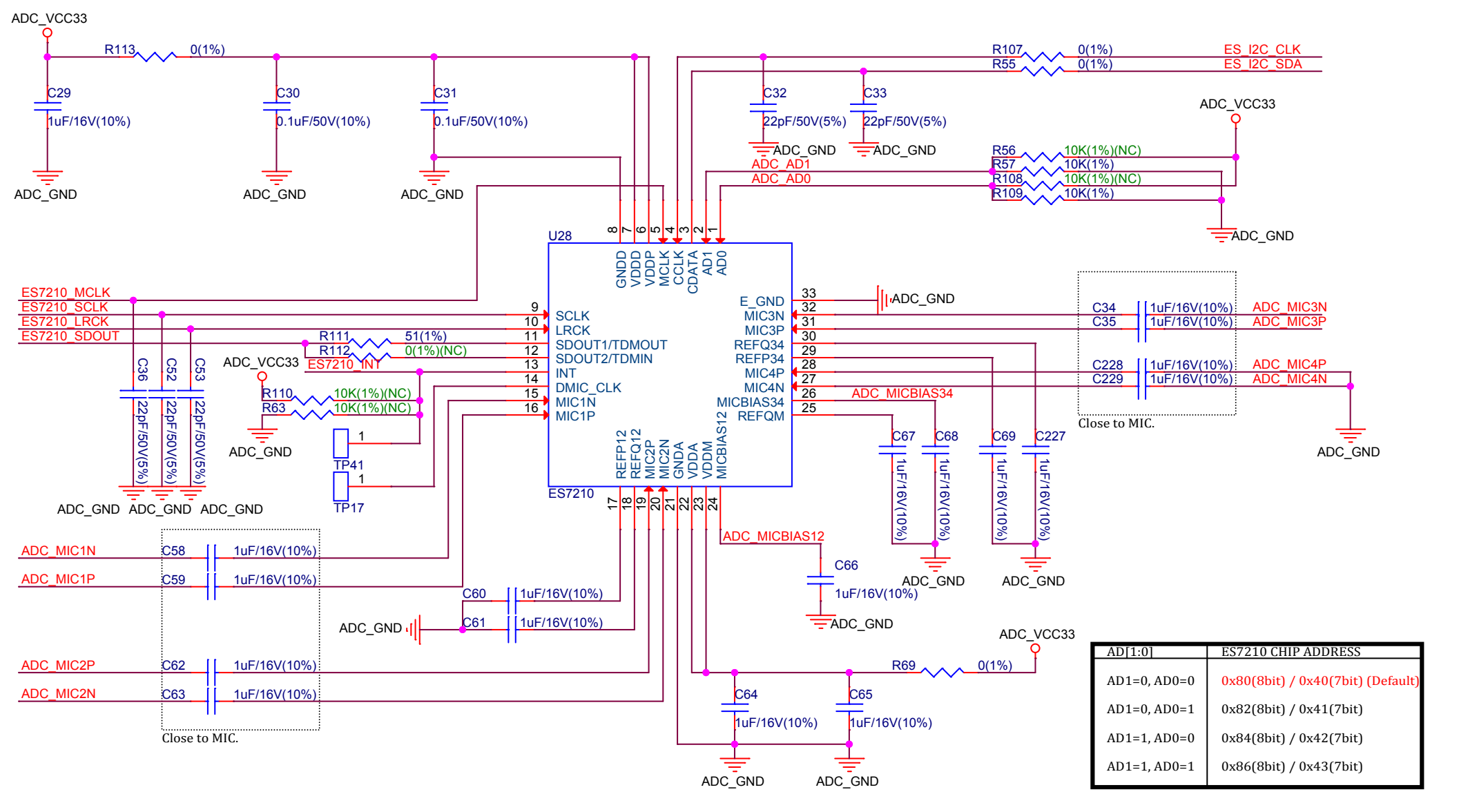

AD1:0	ES7210 CHIP ADDRESS
AD1=0, AD0=0	0x80(8bit) / 0x40(7bit) (Default)
AD1=0, AD0=1	0x82(8bit) / 0x41(7bit)
AD1=1, AD0=0	0x84(8bit) / 0x42(7bit)
AD1=1, AD0=1	0x86(8bit) / 0x43(7bit)

AMICx2:

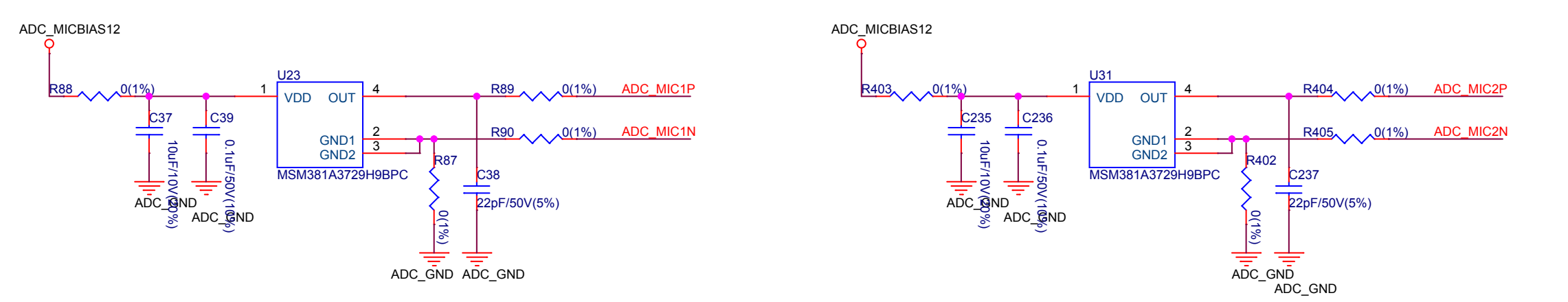

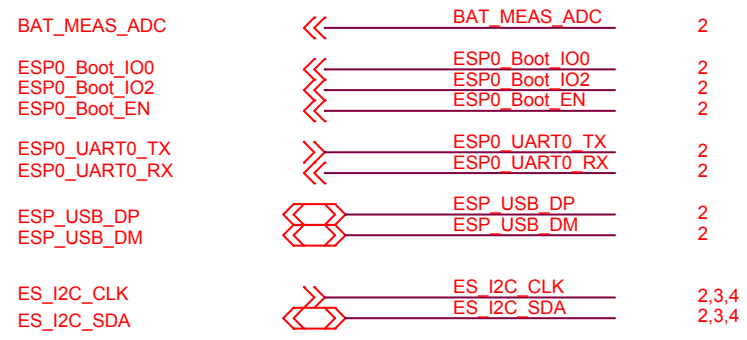

BATTERY:

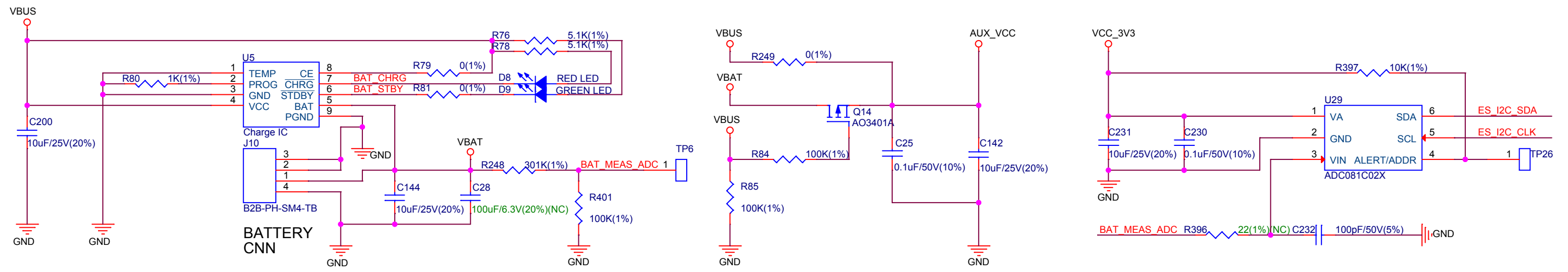

Power IN:

UART:

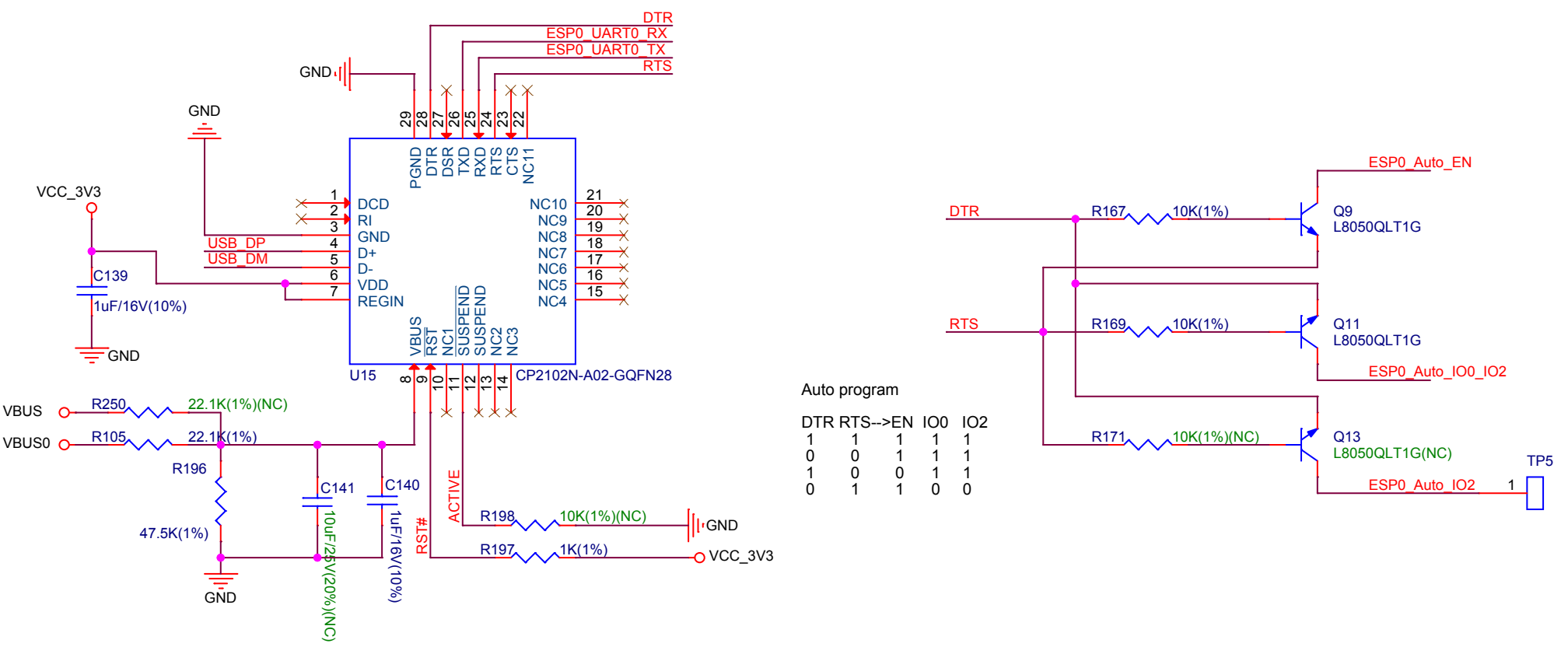
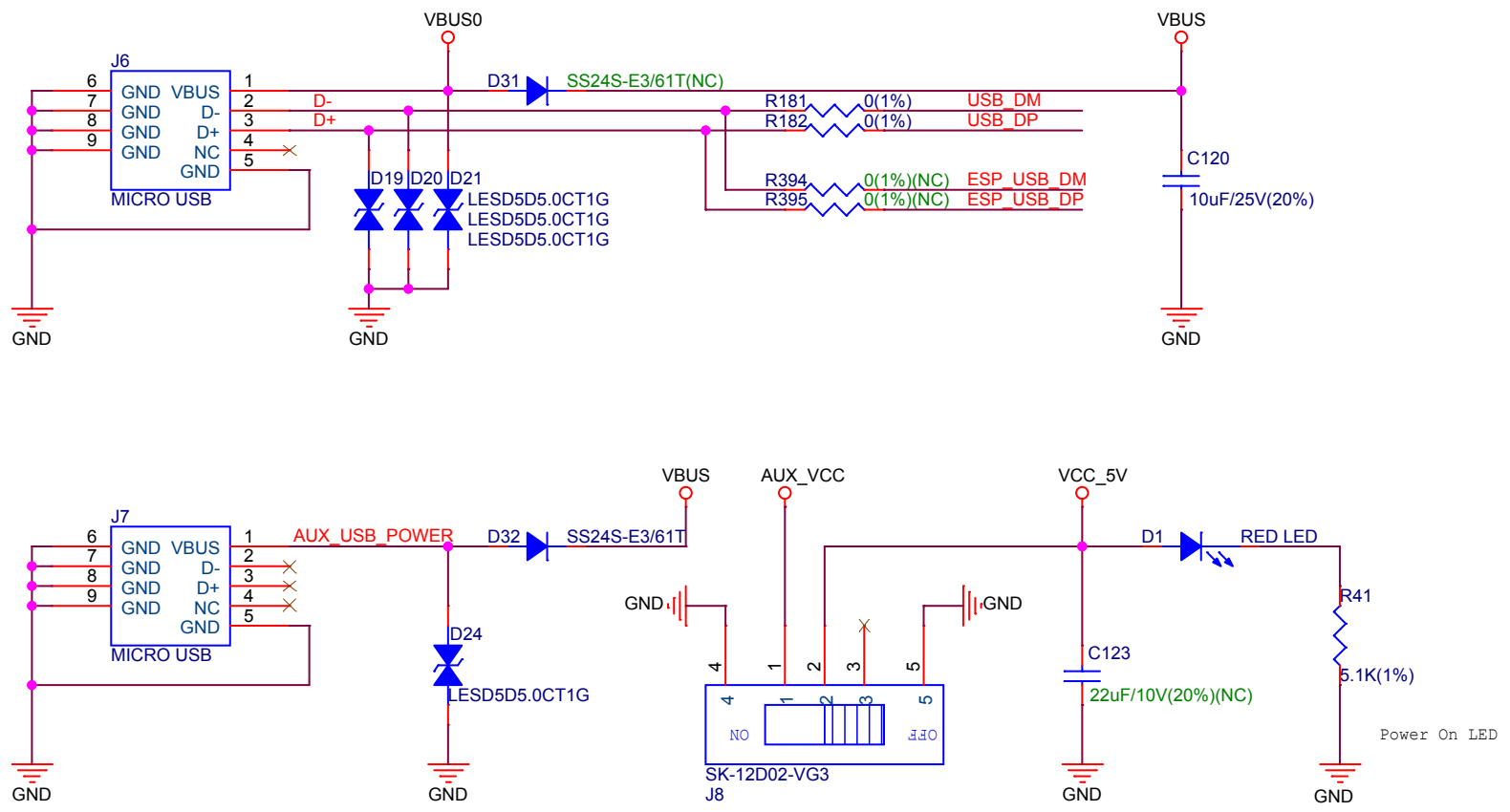

Reset & Download & Button:

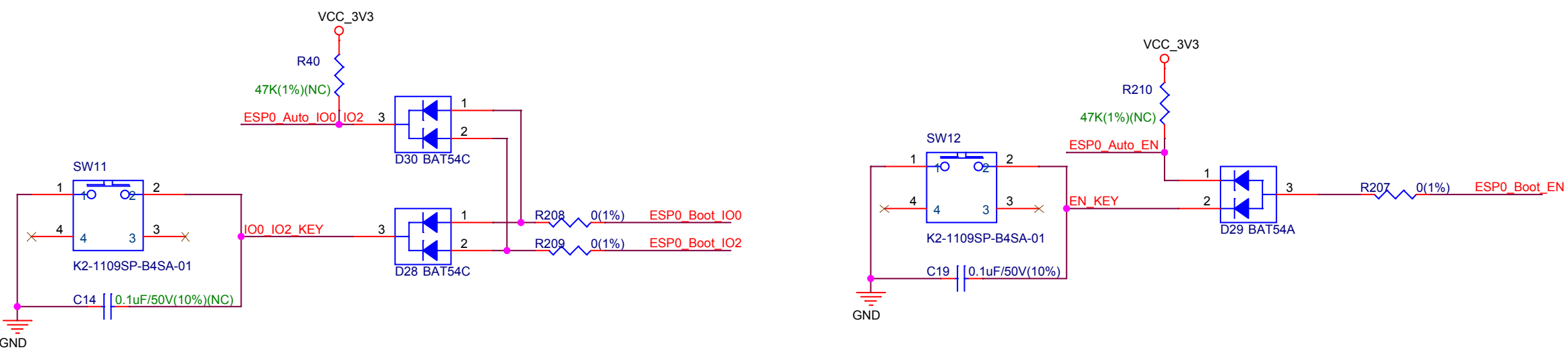

BT_ARRAY_ADC ← BT_ARRAY_ADC 2

Button Array:

